



USER MANUAL – EN

IN 26786 Multi-Game Table 4v1 inSPORTline Highduke

CONTENTS

SAFETY INSTRUCTIONS..... 3
PARTS LIST 3
 ASSEMBLY MATERIAL..... 5
 PRE-ASSEMBLED PARTS 5
ASSEMBLY 6
ENVIRONMENT PROTECTION 18
TERMS AND CONDITIONS OF WARRANTY, WARRANTY CLAIMS..... 18













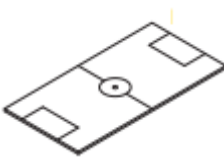



SevenSport s.r.o. reserves the right to make any changes and improvements to its product without prior notice. Visit our website www.insportline.eu where you will find the latest version of the manual.







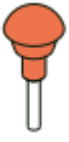

























SAFETY INSTRUCTIONS







- Read the entire manual before assembly and store it for future reference.
- Before assembly, make sure that no parts are missing.
- The game set contains small parts. There is a risk of suffocation.
- Two adults are required to build a table.
- Keep children and pets out of range during assembly. There is a risk of suffocation.
- For home and recreational use.

GAME LIST: Table football, Minigolf, Target shooting, Pinball









PARTS LIST

1.  x2 Side panel	2.  x2 Front panel	3.  x1 Table football	4.  x2 Support brace
5.  x1 Leg - A	6.  x1 Leg - B	7.  x1 Leg - C	8.  x1 Leg - D
9.  x1 Leg side panel – A	10.  x1 Leg side panel – B	11.  x4 Leveling feet	12.  x2 Goal - top
13.  x2 Goal – bottom	14.  x2 Goal net	15.  x11 Player – orange	16.  x11 Player – orange



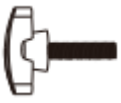





17.  x11 Player – orange	18.  x11 Player – blue	19.  x11 Player – blue	20.  x11 Player – blue
21.  x2 5 - hole rod	22.  x4 3 - hole rod	23.  x2 2 – hole rod	24.  x16 Rod washer
25.  x16 Foam bumper	26.  x4 Stop ring	27.  x8 Rod end cap	28.  x8 Handles
29.  x5 Base	30.  x5 Target board	31.  x1 Playing board	32.  x3 Target – orange
33.  x2 Target – blue	34.  x2 Folding frame	35.  x2 Putter holder	36.  x2 Flag
37.  x2 Score slider	38.  x4 Pinball grip	39.  x1 Putting surface – A	40.  x2 Putting surface – B
41.  x1 Side panel – A	42.  x1 Side panel – B	43.  x1 Side panel – C	44.  x1 Side panel – D
45.  x1 Putting surface – C	46.  x1 Putting surface – D	47.  x9 Connection board	48.  x1 Panel – long

49.  x1 Panel – short	50.  x1 Soccer ball	51.  x1 Blaster	52.  x5 Dart
53.  x2 Putter	54.  x2 Golf ball	55.  x2 Shot ball	

ASSEMBLY MATERIAL

A1  x18 1/4"x1-1/8" Bolt	A2  x16 4x15mm Bolt	A3  x10 4x12mm Bolt	A4  x16 Washer
A5  x14 4x12mm Bolt	A6  x2 1/4"x27mm Bolt	A7  x18 4x18mm Bolt	A8  x8 M5x7mm Bolt
A9  x12 4x35mm Bolt	A10  x1 Allen key		

PRE-ASSEMBLED PARTS

P1  x4 Corner	P2  x16 1/4" Nut	P3  x8 Yellow pinball post	P4  x8 Blue pinball post
P5  x4 5/16" Nut	P6  x2 Left pinball lever	P7  x2 Right pinball lever	P8  x16 Rod bushing
P9  x2 Ball rim			

ASSEMBLY

1. Find a clean, level place to begin the assembly of your product.
2. Verify that you have all listed parts as shown on the parts list pages.

ASSEMBLY

FIG. 1

- 1 x2
Pre-installed
- P8 x16
Pre-installed
- P9 x2
- 2 x1
- A9 x4

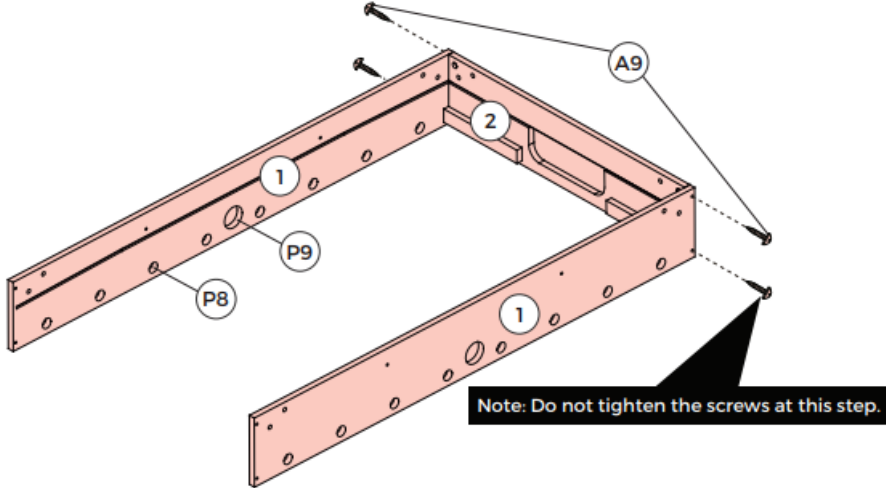

FIG. 2

- 4 x2
- A9 x4

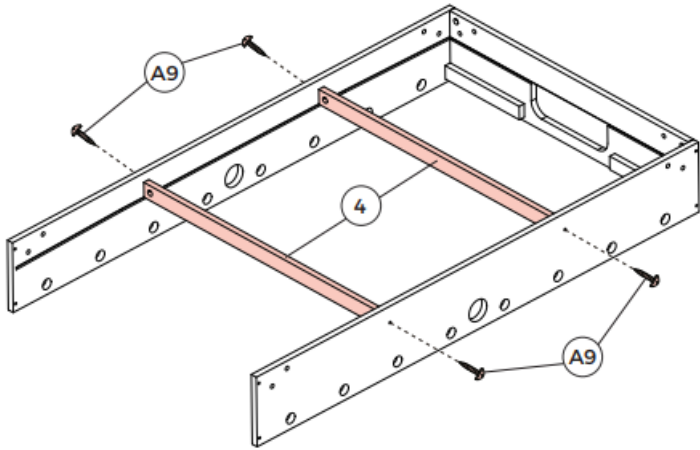
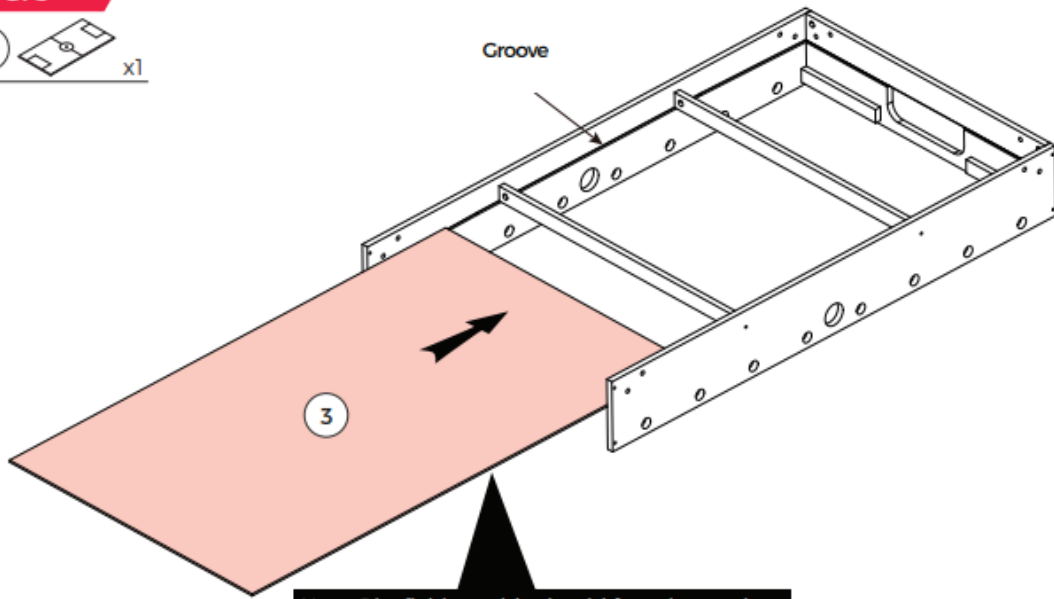
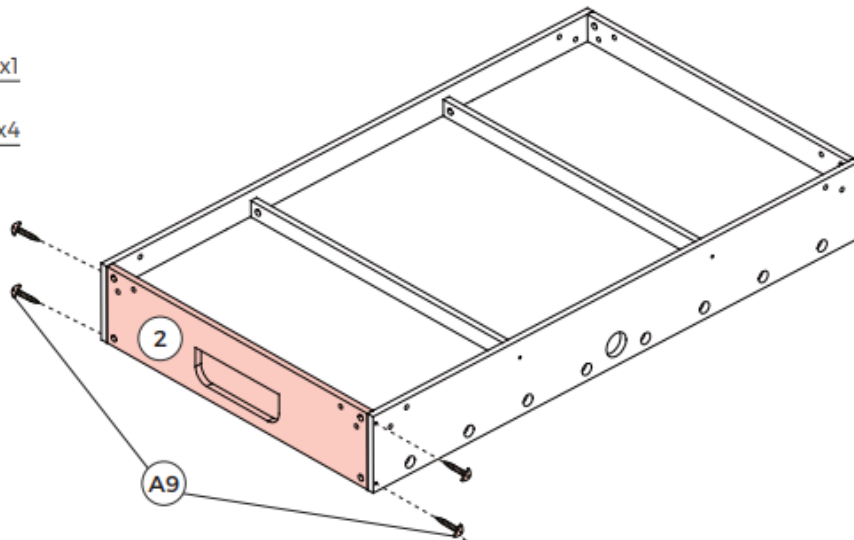

FIG. 3





Note: Playfield graphic should face down when assembling.

FIG. 4



Note: After this step, tighten the Screws (A9).

FIG. 5

- 14  x1
- A5  x2

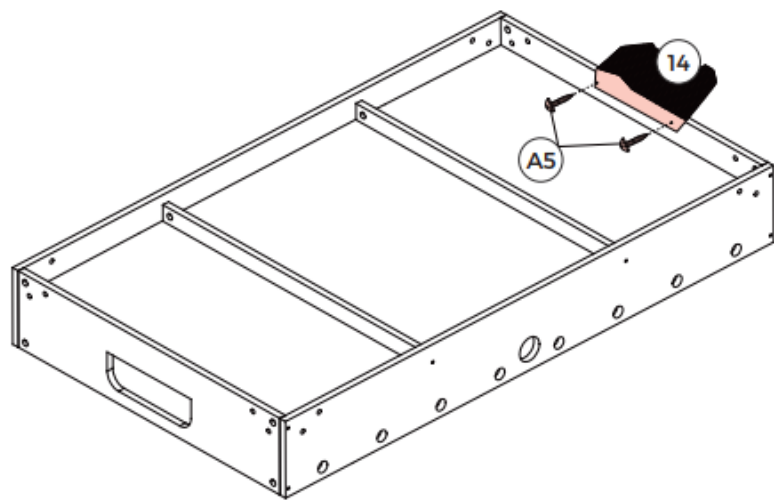











FIG. 6

- 5  x1
- 6  x1
- 7  x1
- 8  x1
- P2  x16
Pre-installed
- P5  x4
Pre-installed
- A1  x16
- A4  x16
- A10  x1

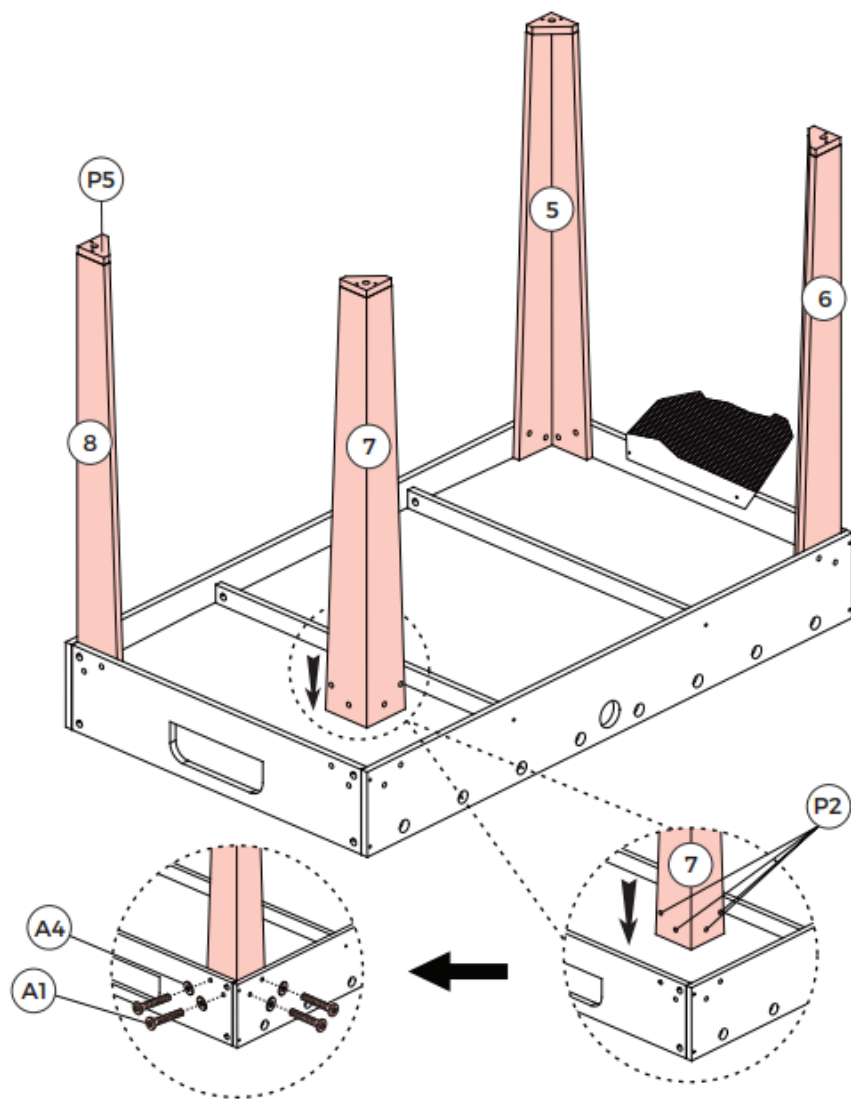



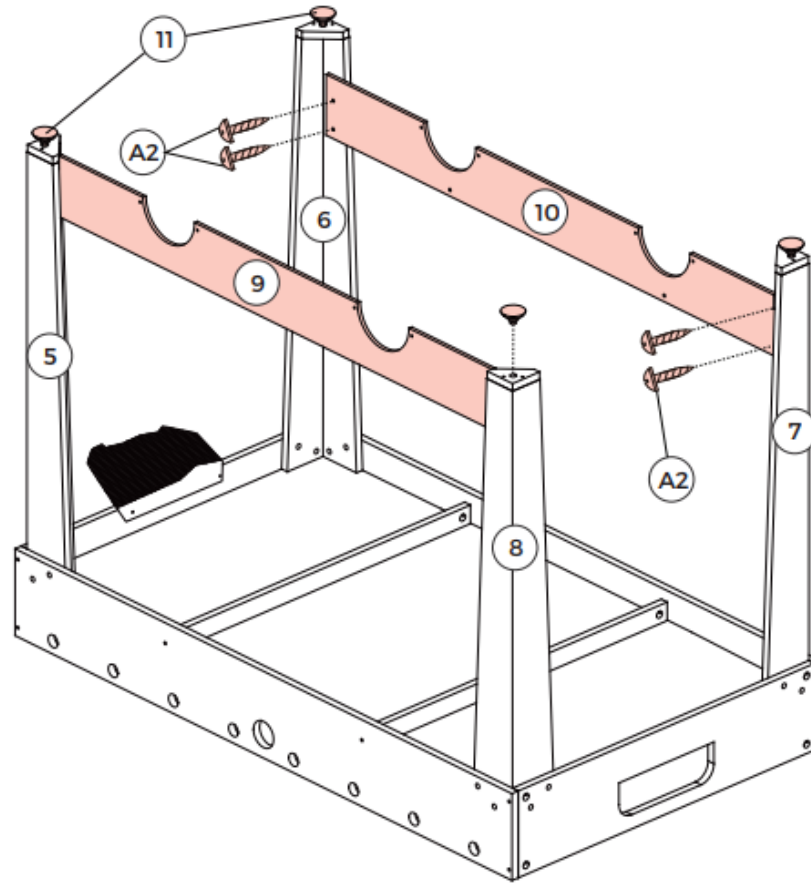
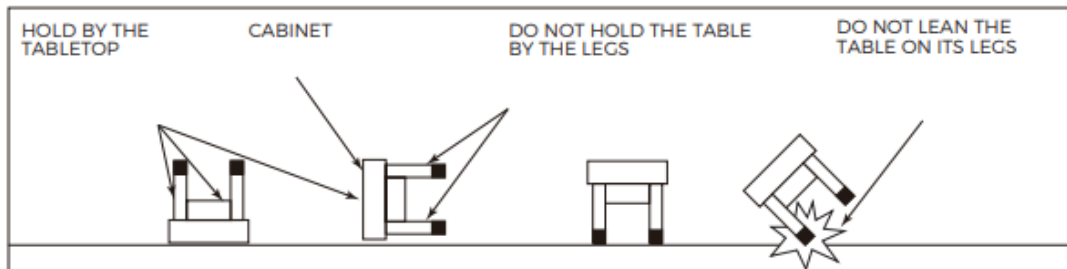

FIG. 7

-  9 x1
-  10 x1
-  11 x4
-  A2 x8





Note: Go back and make sure that all connections are tight.



⚠ CAUTION

- Two strong adults are recommended to turn over the table as shown.
1. Lift the table off the ground.
 2. Turn the table over.
 3. Place it on all feet at the same time on the ground.

FIG. 8

- 15  x11
- 16  x11
- 17  x11
- 18  x11
- 19  x11
- 20  x11
- 21  x2
- 22  x4
- 23  x2
- 24  x16
- 25  x16
- 26  x4
- A8  x8

Note: The Rods have a hole at the end where their Handles will go.

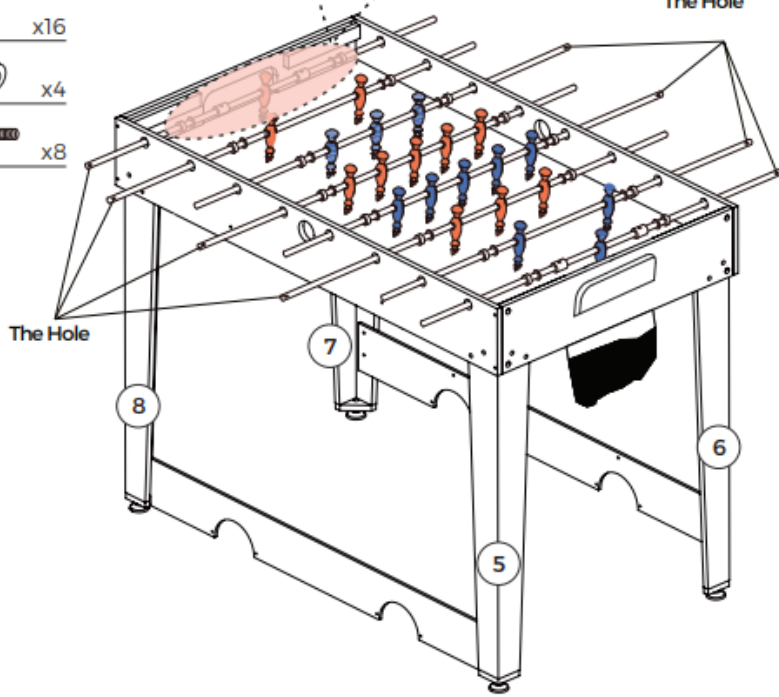
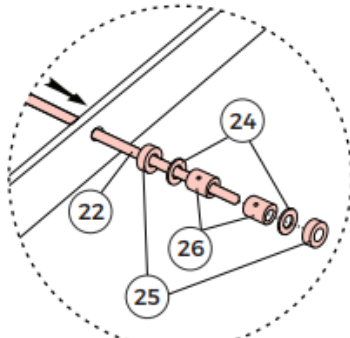
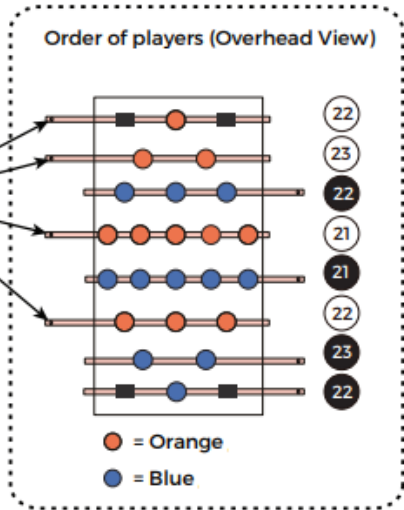

The Hole

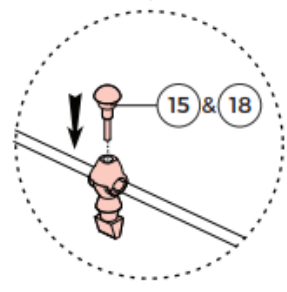
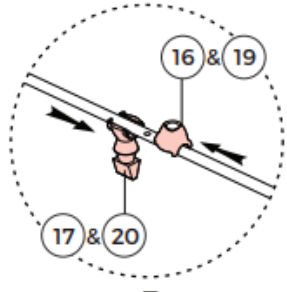
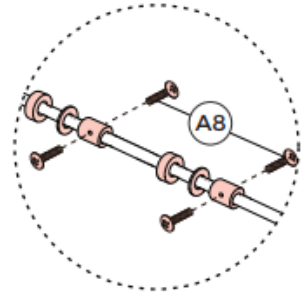

Note: Players of the same team color should have Handles on the same side, and each team's player should be facing their opponent.

FIG. 9

- ①② x2
- ①③ x2
- ②⑦ x8
- ②⑧ x8
- ②A5 x8

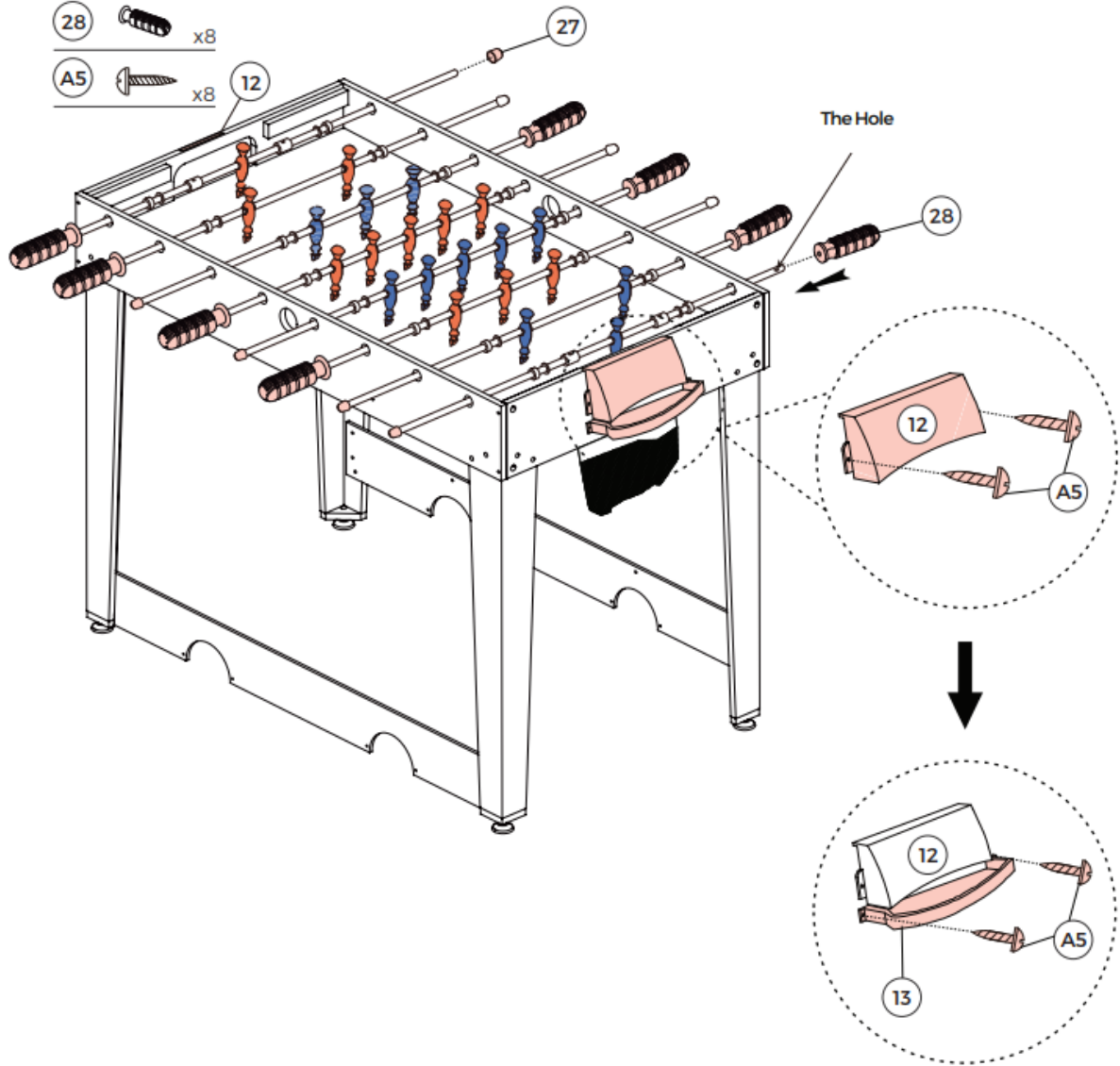

GAME 1 : FOOSBALL

JUEGO1 : FUTBOLITO

FIG. 10

Note: Assemble the Mini Golf.













- 39  x1
- 40  x2
- 41  x1
- 42  x1
- 43  x1
- 44  x1
- 45  x1
- 46  x1
- 47  x9
- 48  x1
- 49  x1
- A7  x18

FIG. 10A Assembly

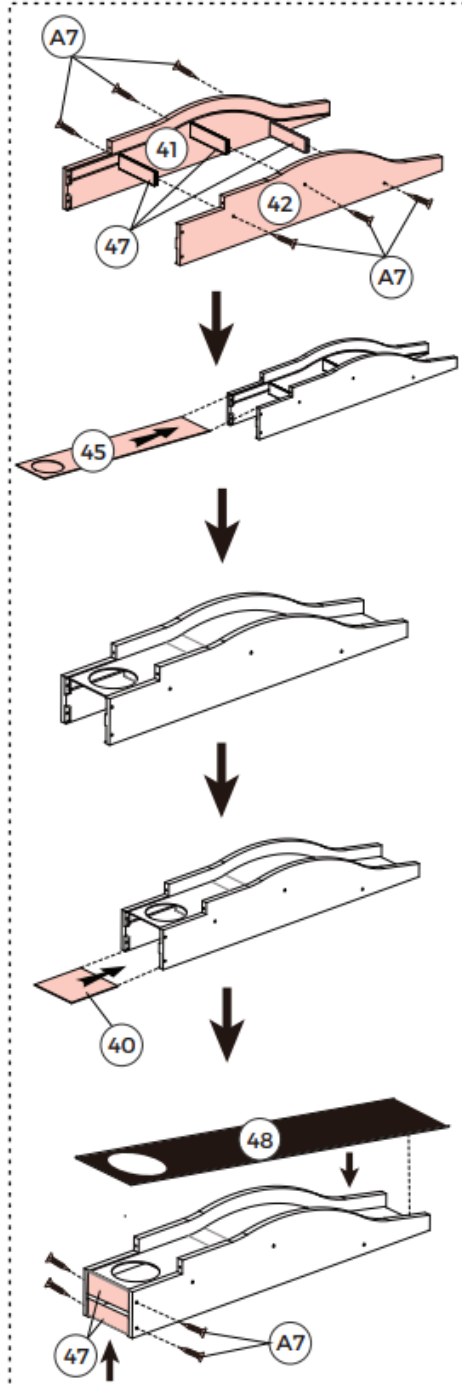

FIG. 10B Assembly

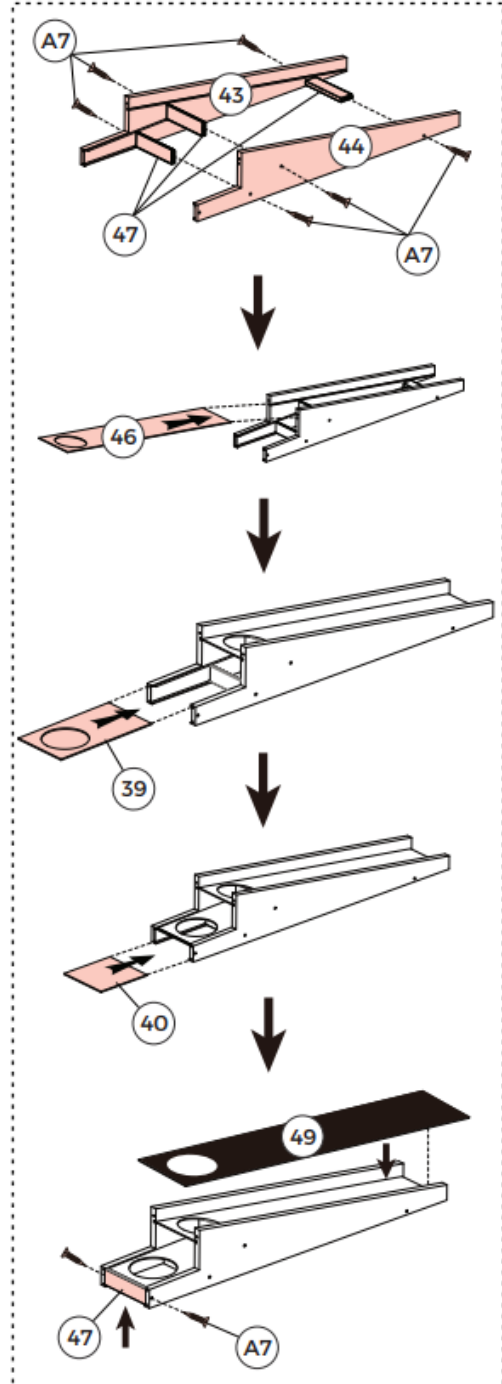

FIG. 11

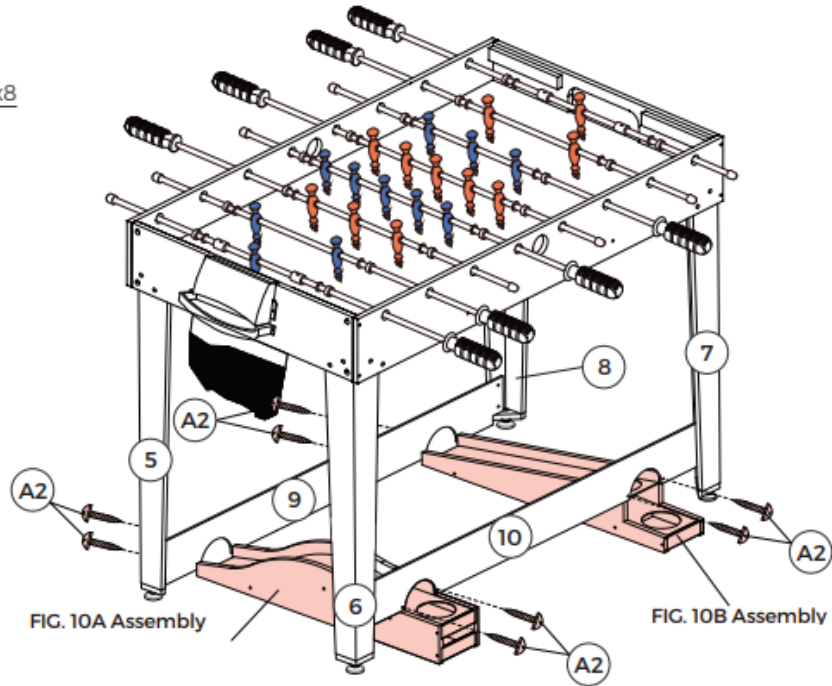
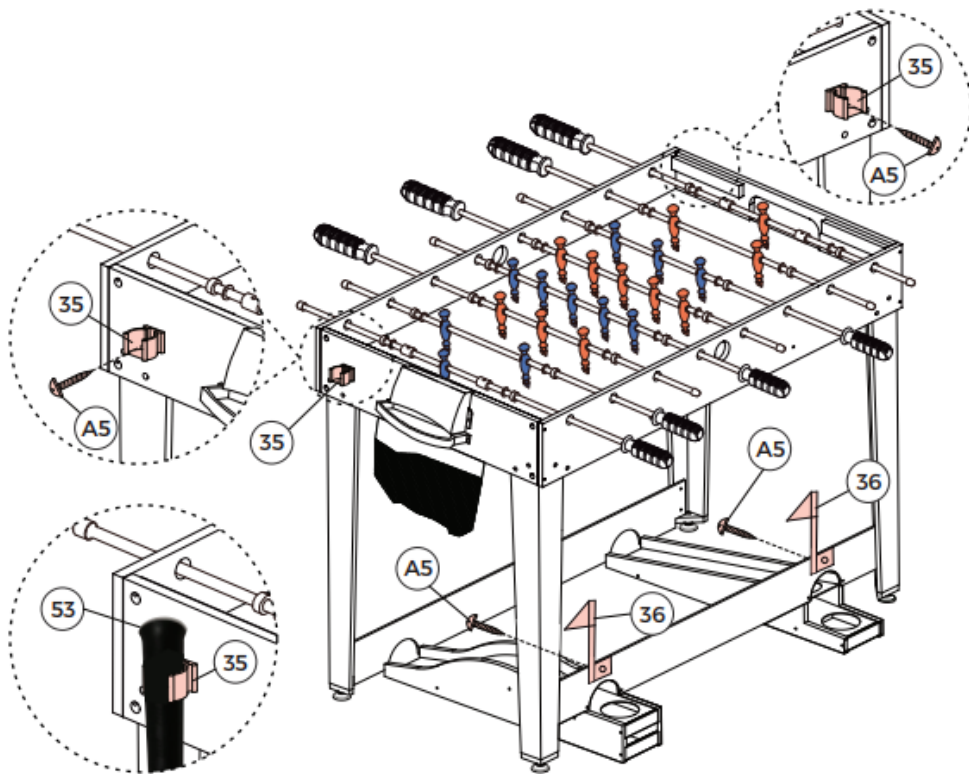
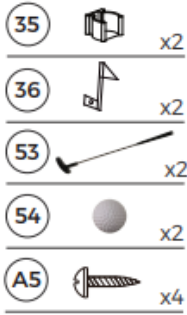

FIG. 12



GAME 2 : MINI-GOLF

JUEGO 2 : MINI-GOLF

FIG. 13

- 29  x5
- 30  x5
- 31  x1
Pre-installed
- P1  x4
- 32  x3
- 33  x2
- A3  x10

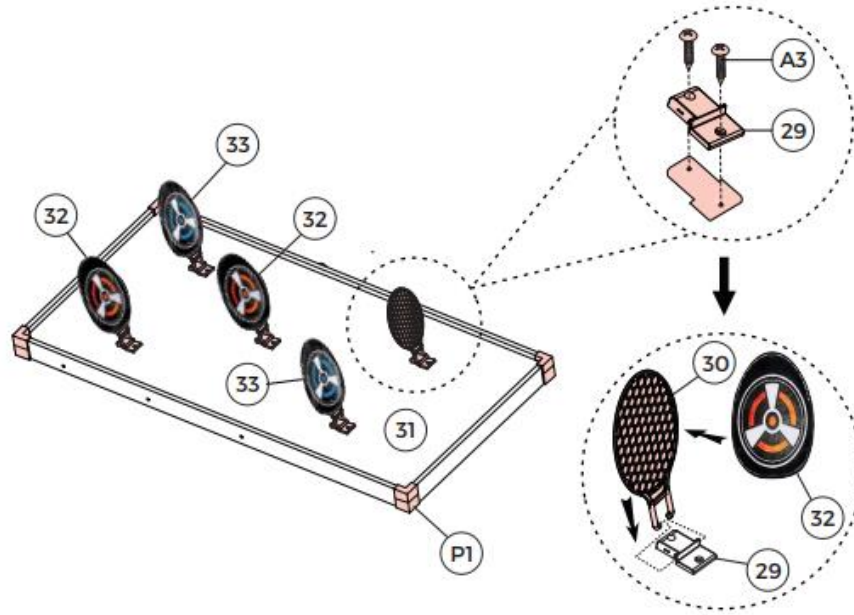





FIG. 14

- 34  x2
- A1  x2
- A6  x2
- A10  x1

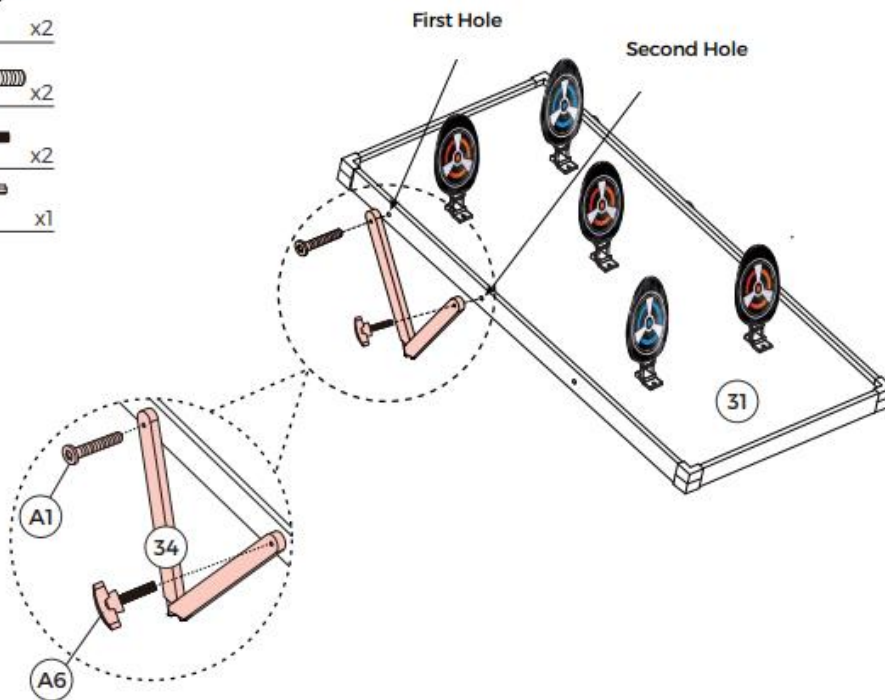

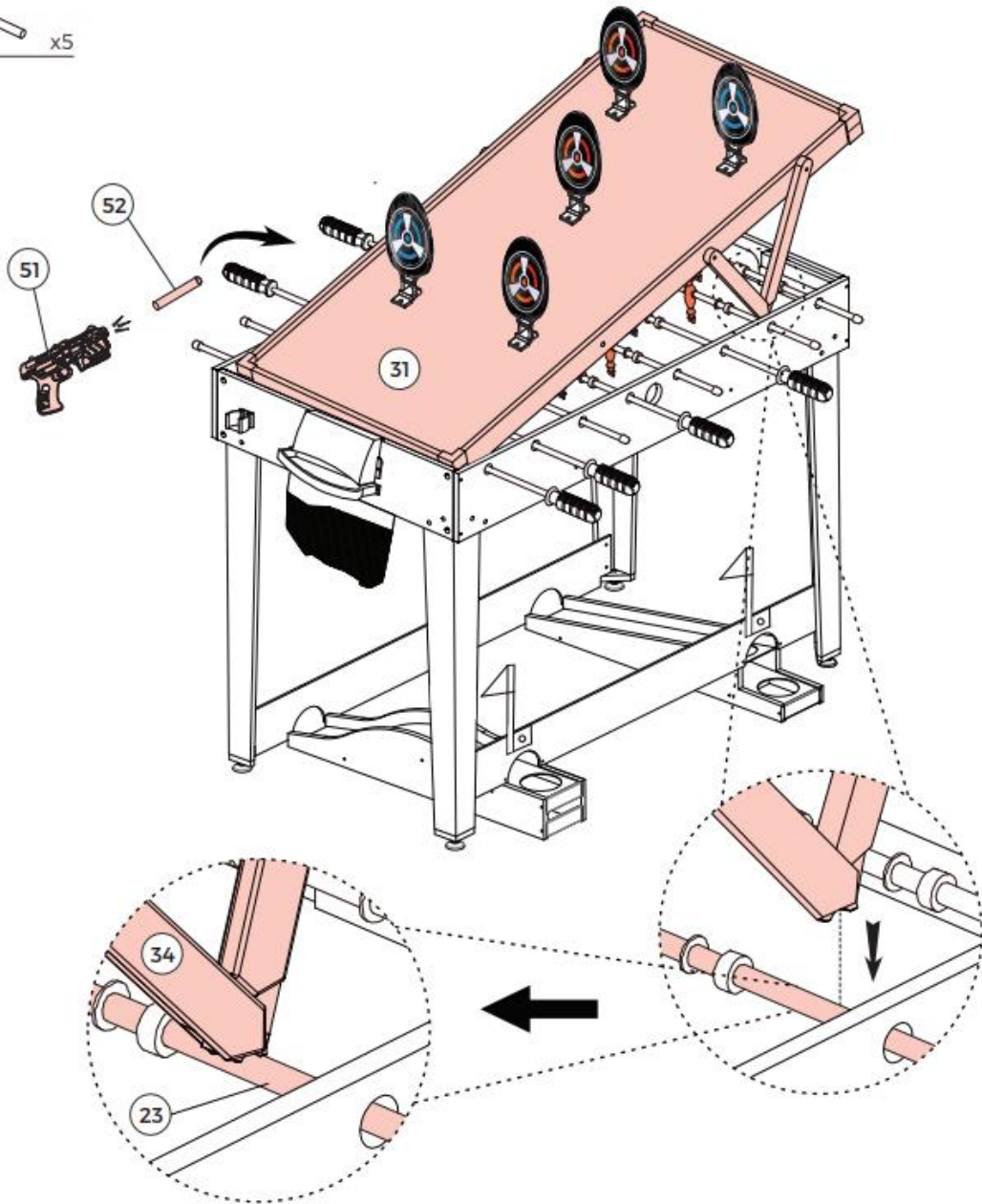

FIG. 15





- 51  x1
- 52  x5



GAME 3 : TARGET SHOOTING

JUEGO 3 : TIRO AL BLANCO

FIG. 16

- P3  Pre-installed x8
- P4  Pre-installed x8
- P6  Pre-installed x2
- P7  Pre-installed x2

Note: Turn over the Playing Board (31).

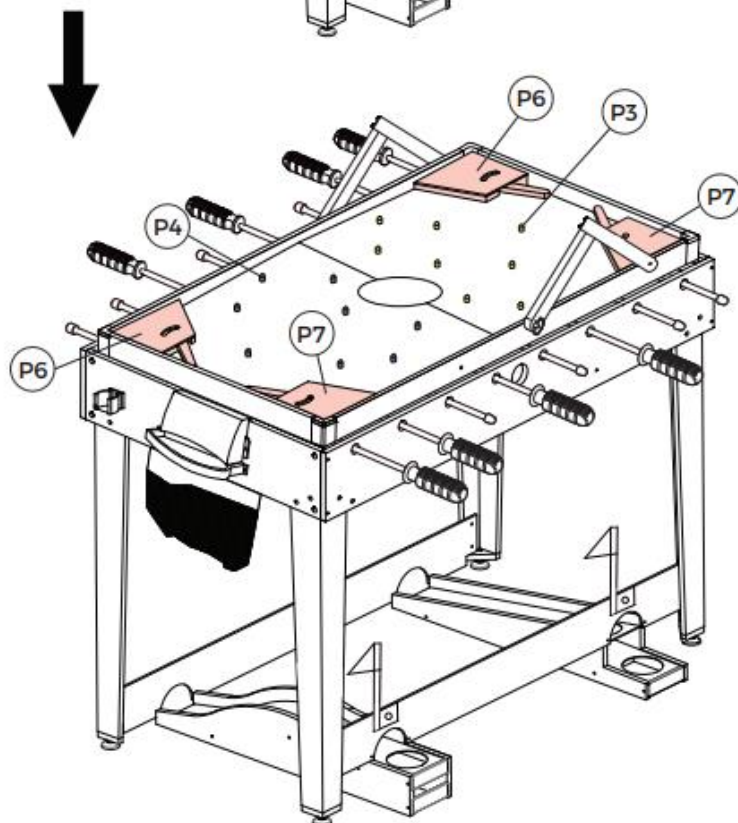
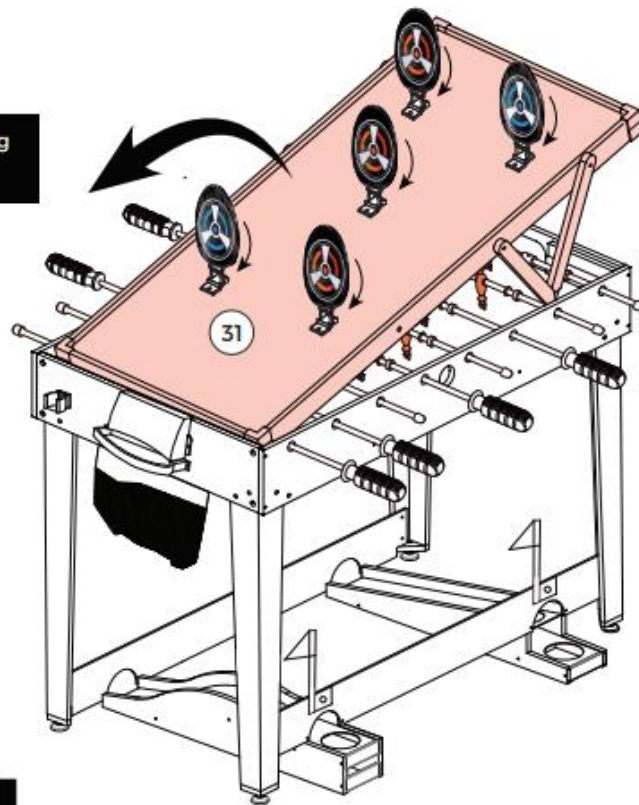
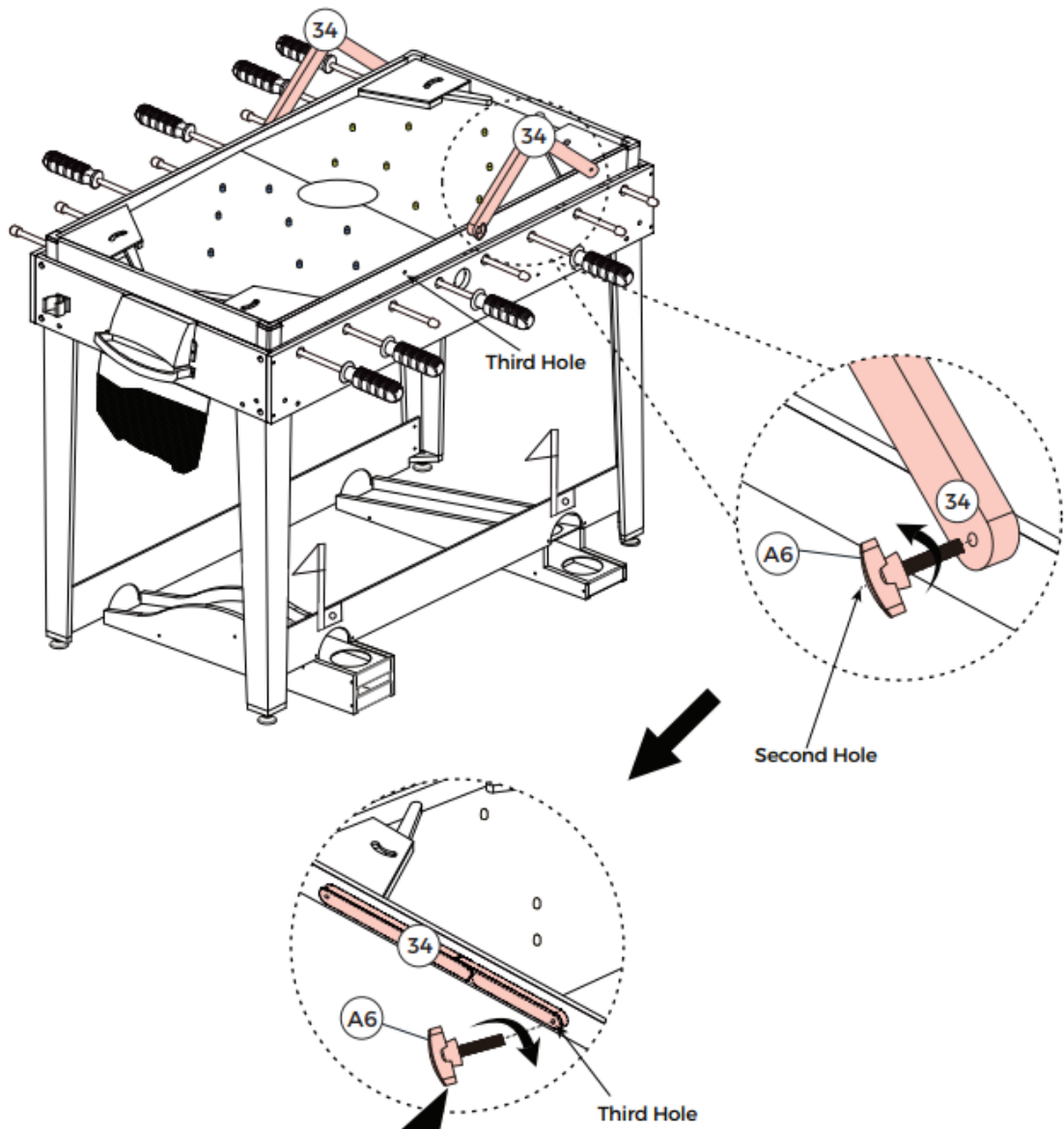





FIG. 17



Note: Pull out the folding supports of the Playing Board (34), then attach them to the Third holes using one Butterfly Bolt (A6) per folding support.

FIG. 18

- 37  x2
- 38  x4
- 55  x2

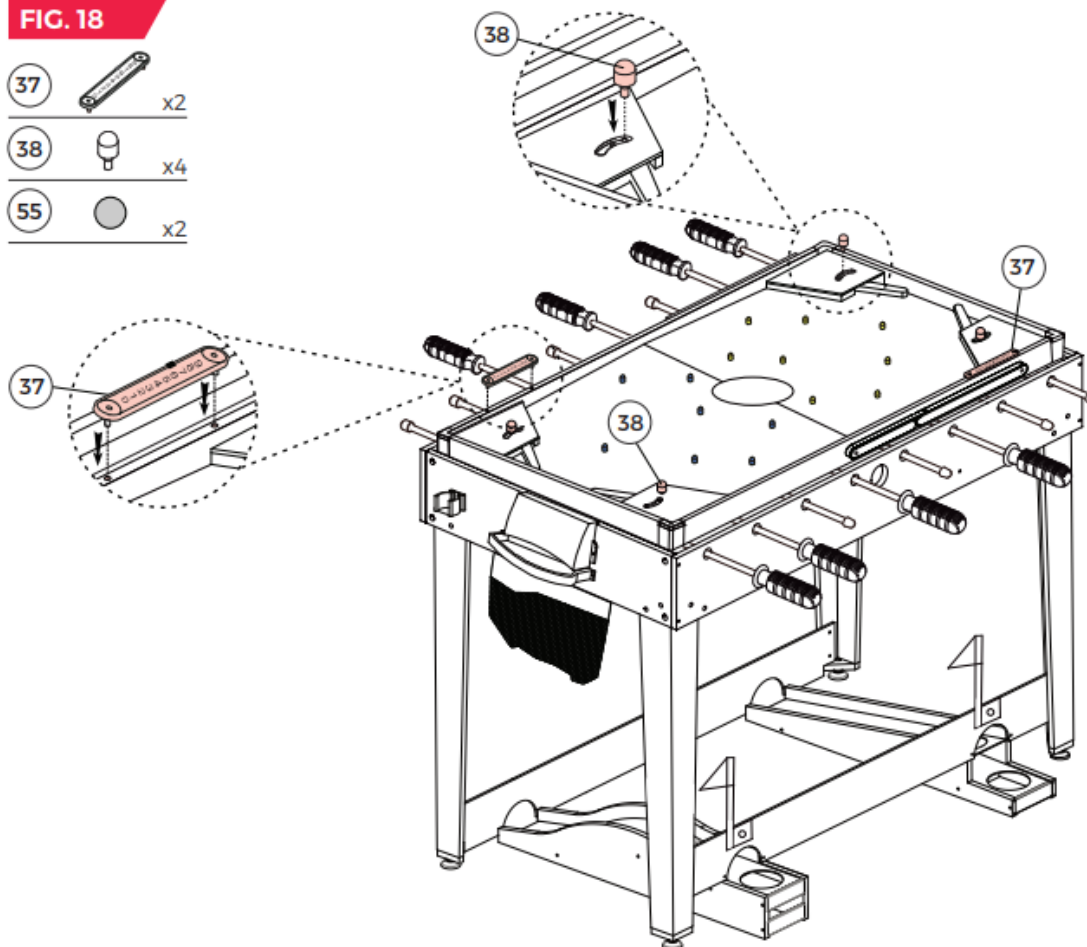

GAME 4 : PINBALL SOCCER

JUEGO 4 : PINBALL

ENVIRONMENT PROTECTION

After the product lifespan expired or if the possible repairing is uneconomic, dispose it according to the local laws and environmentally friendly in the nearest scrapyard.

By proper disposal you will protect the environment and natural sources. Moreover, you can help protect human health. If you are not sure in correct disposing, ask local authorities to avoid law violation or sanctions.

TERMS AND CONDITIONS OF WARRANTY, WARRANTY CLAIMS

General Conditions of Warranty and Definition of Terms

All Warranty Conditions stated here under determine Warranty Coverage and Warranty Claim Procedure. Conditions of Warranty and Warranty Claims are governed by Act No. 89/2012 Coll. Civil Code, and Act No. 634/1992 Coll., Consumer Protection, as amended, also in cases that are not specified by these Warranty rules.

The seller is SEVEN SPORT s.r.o. with its registered office in Strakonická street 1151/2c, Prague 150 00, Company Registration Number: 26847264, registered in the Trade Register at Regional Court in Prague, Section C, Insert No. 116888.

According to valid legal regulations it depends whether the Buyer is the End Customer or not.

“The Buyer who is the End Customer” or simply the “End Customer” is the legal entity that does not conclude and execute the Contract in order to run or promote his own trade or business activities.

“The Buyer who is not the End Customer” is a Businessman that buys Goods or uses services for the purpose of using the Goods or services for his own business activities. The Buyer conforms to the General Purchase Agreement and business conditions.

These Conditions of Warranty and Warranty Claims are an integral part of every Purchase Agreement made between the Seller and the Buyer. All Warranty Conditions are valid and binding, unless otherwise specified in the Purchase Agreement, in the Amendment to this Contract or in another written agreement.

Warranty Conditions

Warranty Period

The Seller provides the Buyer a 24 months Warranty for Goods Quality, unless otherwise specified in the Certificate of Warranty, Invoice, Bill of Delivery or other documents related to the Goods. The legal warranty period provided to the Consumer is not affected.

By the Warranty for Goods Quality, the Seller guarantees that the delivered Goods shall be, for a certain period of time, suitable for regular or contracted use, and that the Goods shall maintain its regular or contracted features.

Batteries

6-month battery warranty – we guarantee that battery's nominal capacity does not fall below 70% of its total capacity within 6 months of the product's sale.

The Warranty does not cover defects resulting from (if applicable):

- User's fault, i.e. product damage caused by unqualified repair work, improper assembly, insufficient insertion of seat post into frame, insufficient tightening of pedals and cranks
- Improper maintenance
- Mechanical damages
- Regular use (e.g. wearing out of rubber and plastic parts, moving mechanisms, joints, wear of brake pads/blocks, chain, tires, cassette/multi wheel etc.)
- Unavoidable event, natural disaster
- Adjustments made by unqualified person
- Improper maintenance, improper placement, damages caused by low or high temperature, water, inappropriate pressure, shocks, intentional changes in design or construction etc.

Warranty Claim Procedure

The Buyer is obliged to check the Goods delivered by the Seller immediately after taking the responsibility for the Goods and its damages, i.e. immediately after its delivery. The Buyer must check the Goods so that he discovers all the defects that can be discovered by such check.

When making a Warranty Claim the Buyer is obliged, on request of the Seller, to prove the purchase and validity of the claim by the Invoice or Bill of Delivery that includes the product's serial number, or eventually by the documents without the serial number. If the Buyer does not prove the validity of the Warranty Claim by these documents, the Seller has the right to reject the Warranty Claim.

If the Buyer gives notice of a defect that is not covered by the Warranty (e.g. in the case that the Warranty Conditions were not fulfilled or in the case of reporting the defect by mistake etc.), the Seller is eligible to require a compensation for all the costs arising from the repair. The cost shall be calculated according to the valid price list of services and transport costs.

If the Seller finds out (by testing) that the product is not damaged, the Warranty Claim is not accepted. The Seller reserves the right to claim a compensation for costs arising from the false Warranty Claim.

In case the Buyer makes a claim about the Goods that is legally covered by the Warranty provided by the Seller, the Seller shall fix the reported defects by means of repair or by the exchange of the damaged part or product for a new one. Based on the agreement of the Buyer, the Seller has the right to exchange the defected Goods for a fully compatible Goods of the same or better technical characteristics. The Seller is entitled to choose the form of the Warranty Claim Procedures described in this paragraph.

The Seller shall settle the Warranty Claim within 30 days after the delivery of the defective Goods, unless a longer period has been agreed upon. The day when the repaired or exchanged Goods is handed over to the Buyer is considered to be the day of the Warranty Claim settlement. When the Seller is not able to settle the Warranty Claim within the agreed period due to the specific nature of the Goods defect, he and the Buyer shall make an agreement about an alternative solution. In case such agreement is not made, the Seller is obliged to provide the Buyer with a financial compensation in the form of a refund.

CZ
SEVEN SPORT s.r.o.

Registered Office: Strakonická 1151/2c, Praha 5, 150 00,
ČR

Headquarters: Dělnická 957, Vítkov, 749 01

Warranty & Service: Čermenská 486, Vítkov 749 01

CRN: 26847264

VAT ID: CZ26847264

Phone: +420 556 300 970

E-mail: eshop@insportline.cz
reklamace@insportline.cz
servis@insportline.cz

Web: www.inSPORTline.cz

SK
inSPORTline s.r.o.

Headquarters, warranty & service center: Električná 6471,
Trenčín 911 01, SK

CRN: 36311723

VAT ID: SK2020177082

Phone: +421(0)326 526 701

E-mail: objednavky@insportline.sk
reklamacie@insportline.sk
servis@insportline.sk

Web: www.inSPORTline.sk

About shipping

