

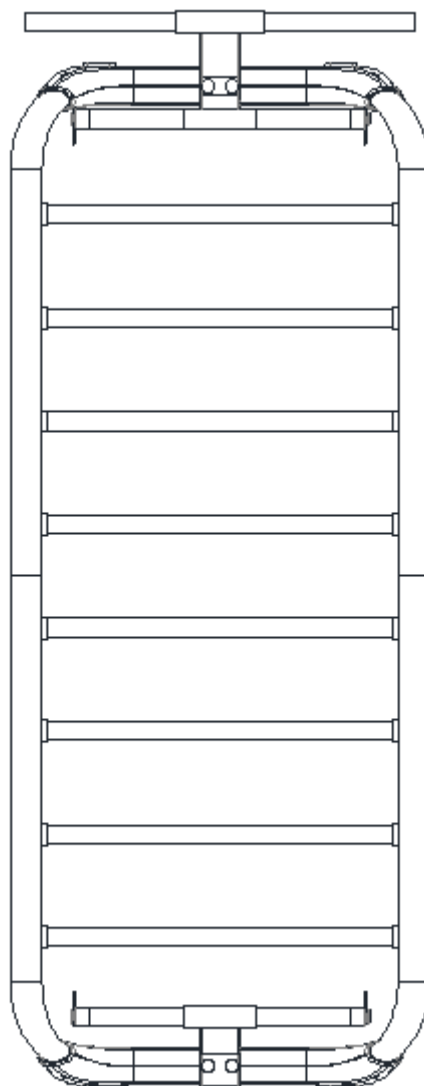

USER MANUAL – EN

IN 26736 Wall bars inSPORTline Wootalux 220x86 cm



CONTENTS

SAFETY INSTRUCTIONS..... 3
PRODUCT DESCRIPTION 4
ASSEMBLY 5
EXERCISE INSTRUCTIONS 7
PARTS LIST 8
DIAGRAM 9
ENVIRONMENT PROTECTION 10
TERMS AND CONDITIONS OF WARRANTY, WARRANTY CLAIMS..... 10

SevenSport s.r.o. reserves the right to make any changes and improvements to its product without prior notice. Visit our website www.insportline.eu where you will find the latest version of the manual.

SAFETY INSTRUCTIONS

- Please read the manual before use and keep it for future reference.
- Follow all limits and do not exceed them. Use only for the purposes for which the product is made.
- Check that all screws and connections are tight before use.
- Consult your doctor before any training program.
- Do not exercise immediately after eating.
- Always wear appropriate sports clothing and footwear.
- Warm up before exercising.
- Children or persons with limited motor or mental abilities may only use the product under the supervision of an adult.
- Do not repair or modify the product yourself.
- Do not use damaged or worn equipment. If sharp edges appear on the product, stop using the product.
- Keep out of reach of children, this is not a toy. Never leave children unattended near wall bars. There is a risk of choking or inhaling small parts.
- Assembly may only be carried out by an adult.
- Do not exercise under the influence of drugs or alcohol.
- Use a soft cloth to clean. After each exercise, wipe sweat from the device.
- For internal use only.
- Use: H – home use
- Load capacity: 150 kg
- Place the product on a firm, flat and clean surface. For better safety, keep a distance of min. 0.6 m from other room equipment. The product must be attached (anchored) to the wall. The method of correct attachment also depends on the material composition of the wall. If you are unsure, consult a professional for proper installation.

PRODUCT DESCRIPTION

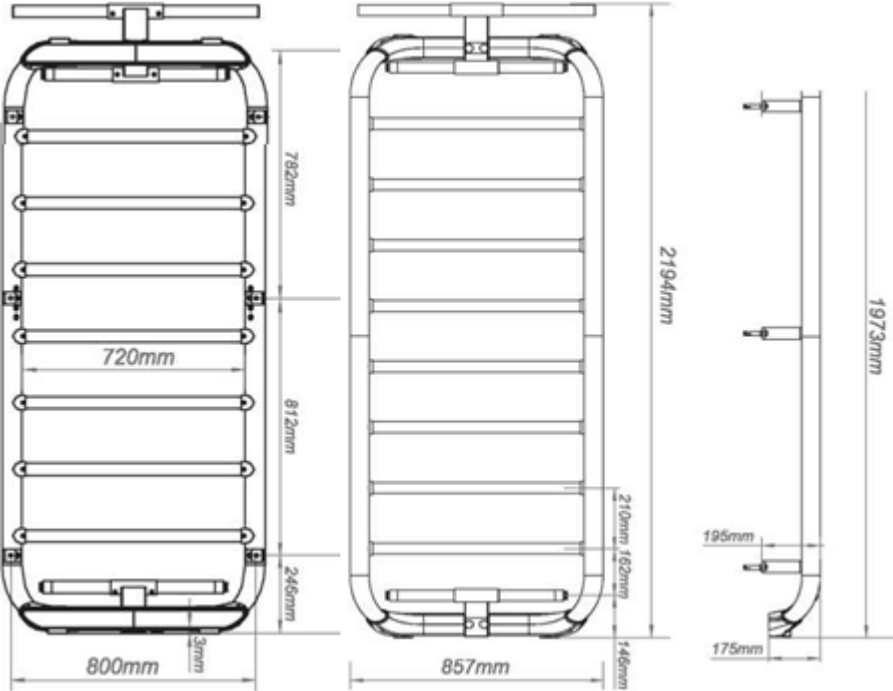

Expanded dimension	2194x857x421(mm)
Weight (gross/net)	41KGS/36KGS

ASSEMBLY

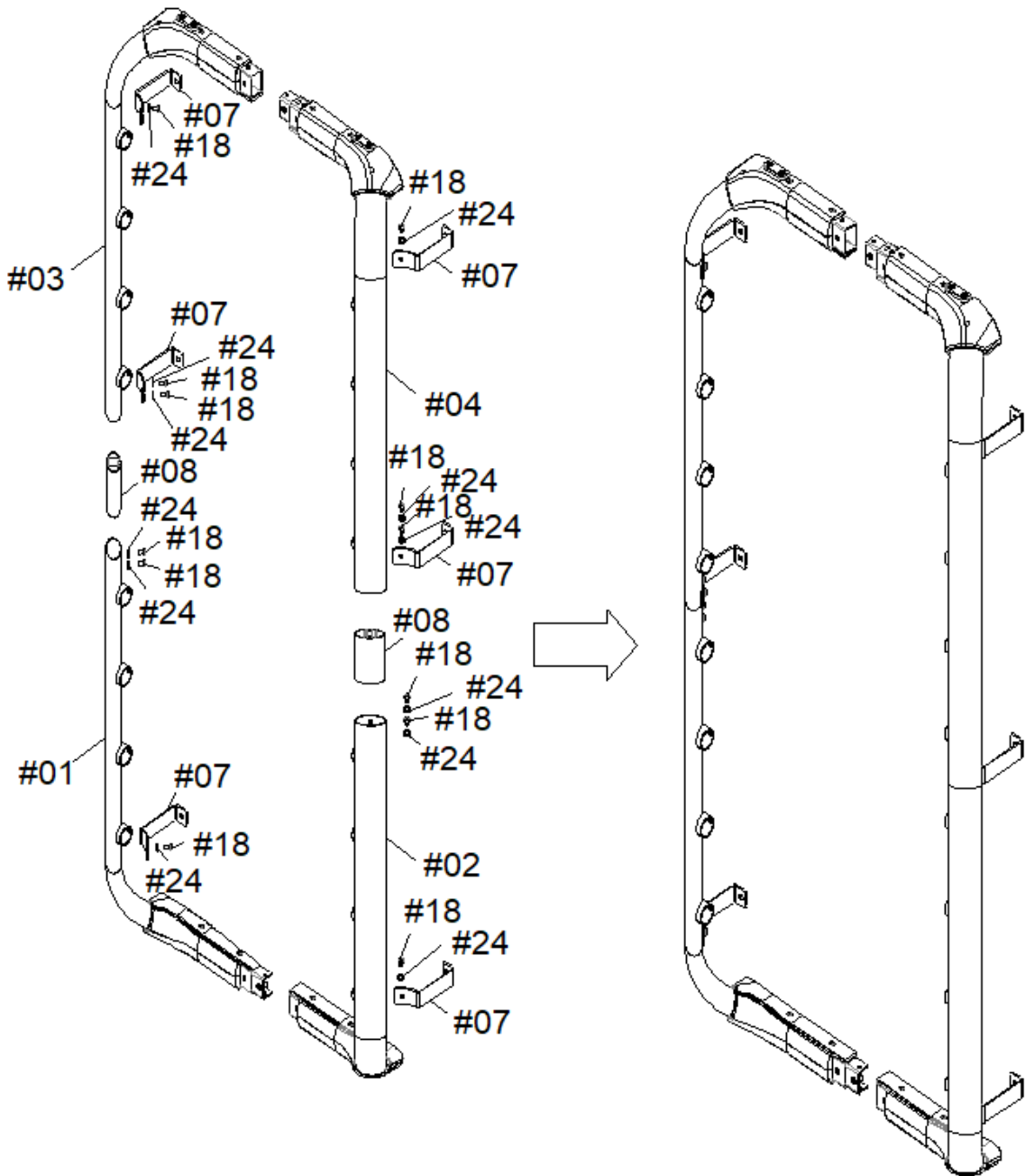

Attach the connecting frame (08) to the lower frame (01) using screws (18), washers (24) and a wrench (28).

Attach the upper frame (03) to the connecting frame (08) using screws (18), washers (24) and a wrench (28).

Attach the brackets (07) to the upper and lower frames using screws (18) and washers (24).

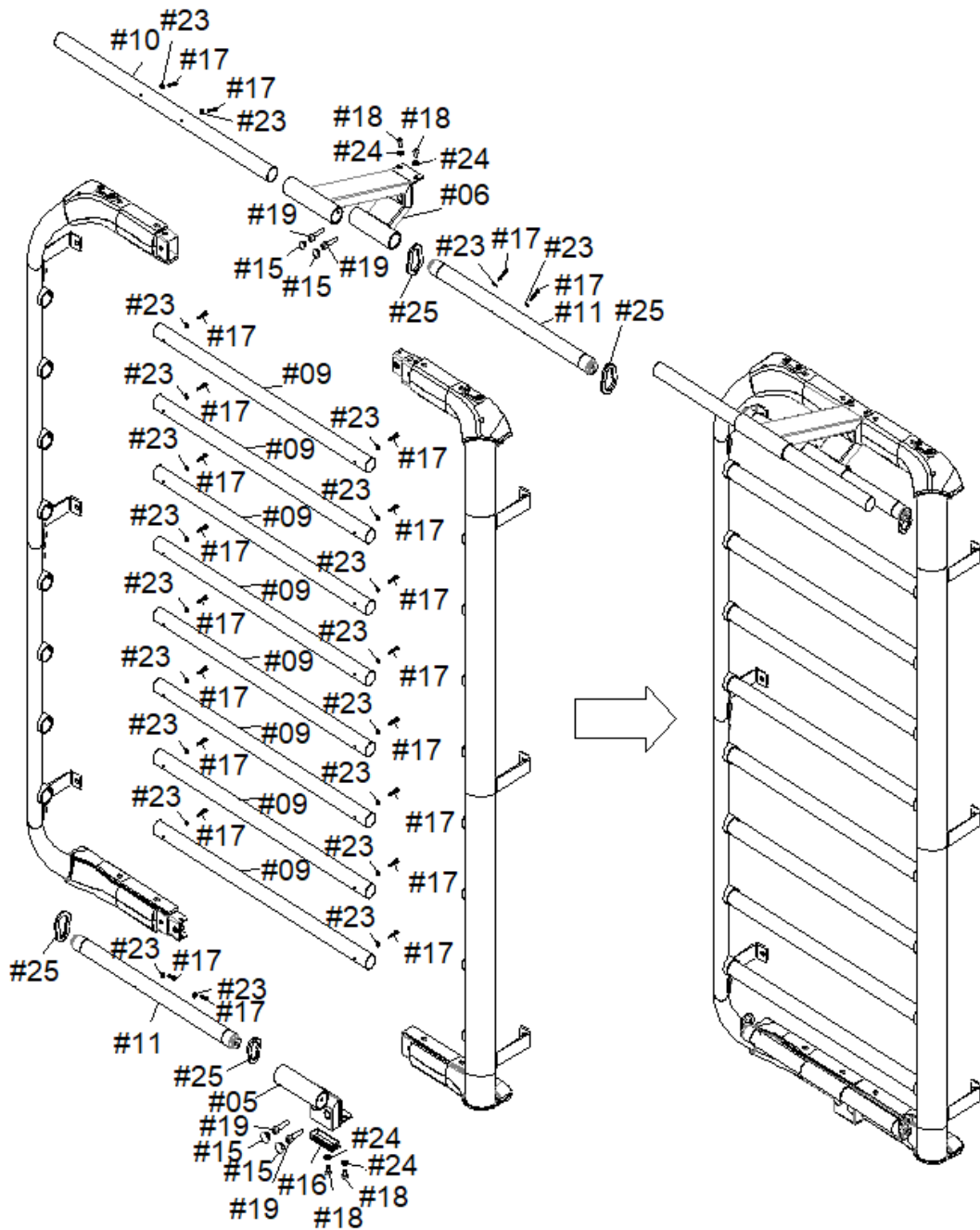

Attach the bar (11) to the step holder (05) using screws (17), washers (23) and cover (16).

Attach the bars (10 – upper and 11 – lower) to the pull up bar frame (06) using screws (17) and washers (23).

Attach the bars (9) to one side of the frame and then slide into the brackets on the other frame.

Attach the step holder (5) to the bottom of the frame with screws (19). attach the caps (15) to the screws and then screw the screws (18) and washers (24) from the bottom side.

Attach the pull up bar frame (6) with the screw (19) to the screws, fix the covers (15) and then screw the screws (18) and the washers (34) from the bottom side.

Align the holes on the bars (9) with the holes in the bracket and secure on both sides with screws (17) and washers (23).

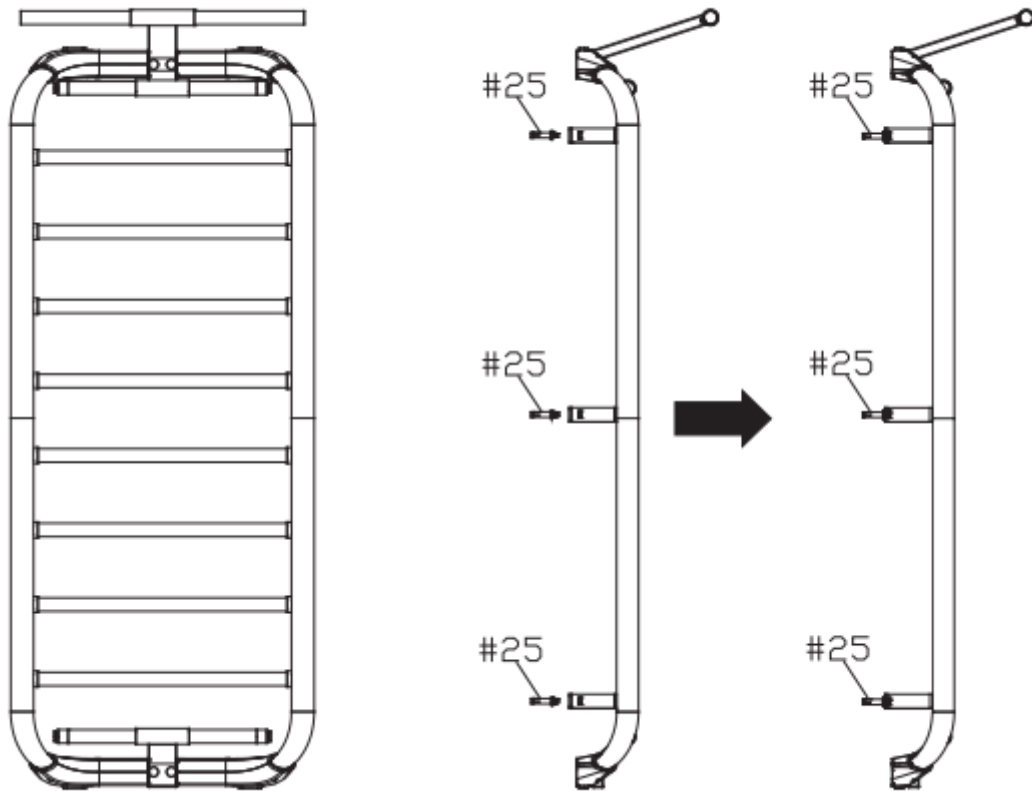

Attach the wall bars to the prepared holes in the wall using a dowel and expansion screws (M8*80 mm).

EXERCISE INSTRUCTIONS

Exercise is beneficial to your health, improves physical condition, shapes muscles and, in combination with a calorie-balanced diet, leads to weight loss.

1. WARM UP

This phase serves to improve the blood circulation of the whole body and to warm up the muscles, to reduce the risk of convulsions and muscle injury. We recommend performing the stretching exercises below. When dragging, stay in the end position for approximately 30 seconds, do not make sudden movements and do not vibrate.

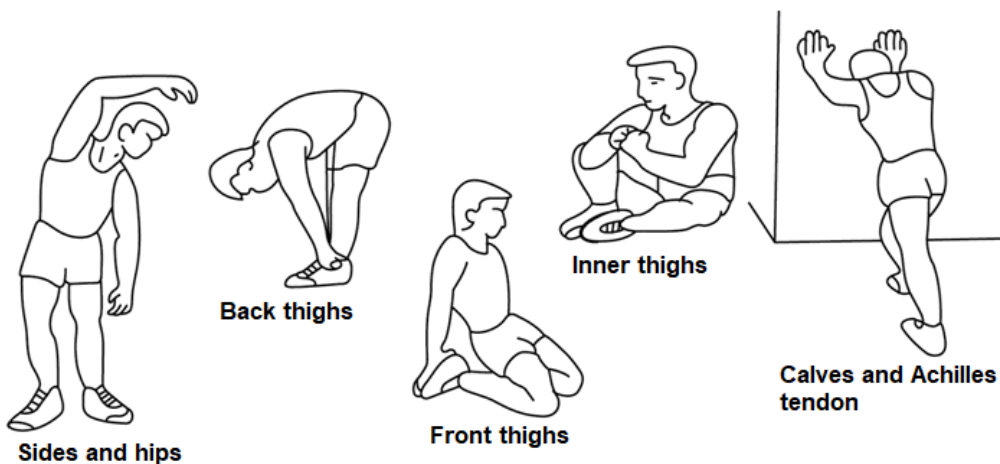

2. EXERCISING

This phase is the most physically demanding part. Regular exercise strengthens the muscles. You can determine the tempo yourself, but it is very important that it is the same throughout the exercise. Heart rate should be within the target zone (see figure below).

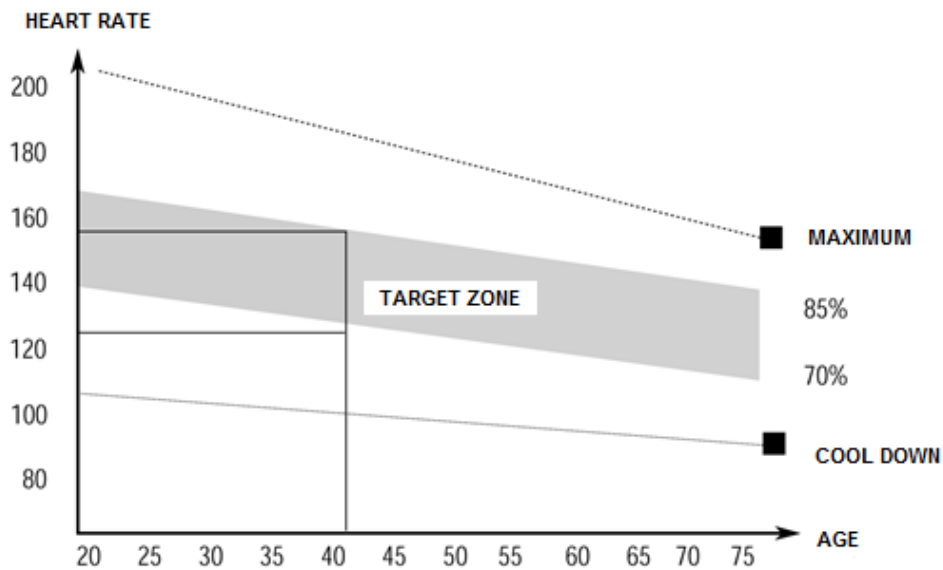

This phase should last at least 12 minutes. Most people exercise for 15-20 minutes.

3. COOLDOWN

This phase serves to soothe the cardiovascular system and relax the muscles. It should take approximately 5 minutes. You can repeat warming up exercises or continue exercising at slower pace. Stretching your muscles after exercise is extremely important - you need to avoid sudden movements and vibrations.

With improved fitness, you can lengthen and increase exercise intensity. Train regularly, at least three times a week.

SHAPING MUSCLES

For muscle shaping, it is important to set a high load. The muscles will be more stressed, which may cause that you will not be able to exercise as long as usual. If you are trying to improve your condition at the same time, you need to adjust your training. Exercise in the usual way during the warm-up and final stages of training but increase the resistance of the device at the end of the exercise. You may need to slow down the speed to keep the heart rate in the target area.

WEIGHT LOSS

The number of calories burned depends on the length and intensity of the exercise. The essence is the same as in fitness exercise, but the goal is different.

PARTS LIST

No.	Name	Qty.	No.	Name	Qty.
01	Bottom left frame	1	13-3	Cover - C	2
02	Lower right frame	1	13-3	Cover - D	2
03	Upper left frame	1	14	Opera	4
04	Upper lower frame	1	15	Screw caps	4
05	Step holder	1	16	Square cap 40*80*T2.0	1
06	Trapeze frame	1	17	M5*30 screw	26

07	Fixing plate	6	18	M8*15 screw	16
08	Aluminum connecting frame	2	19	M10*30 screw	4
09	Partition *38*800L	8	20	M6*20 screw	8
10	Trapeze φ38*800L	1	21	M5*15 screw	16
11	Lower crossbar *38*600L	2	22	M4*15 screw	4
12	Aluminum sleeve	4	23	Flat washer φ5.5*φ12*T1.0	22
13-1	Cover - A	2	24	Flat washer φ8.5*φ16*T1.6	16
13-2	Cover - B	2	25	Carbine	4

DIAGRAM

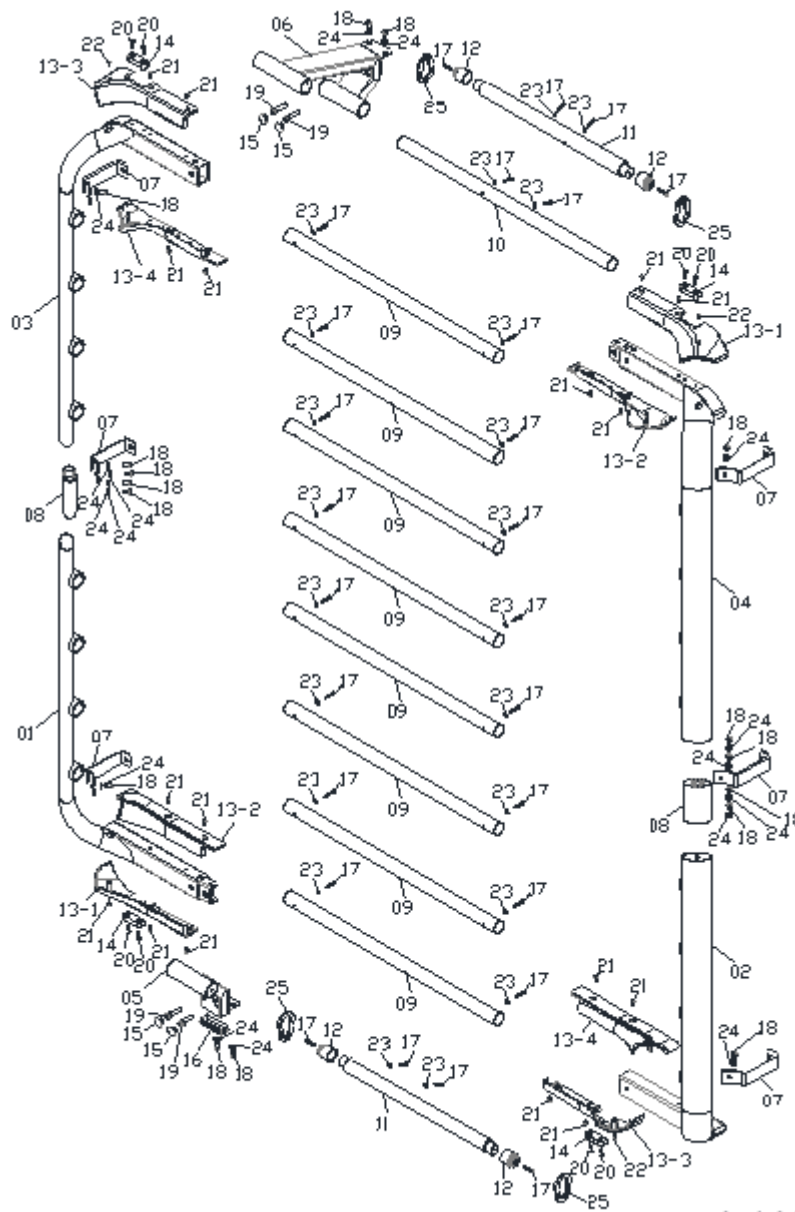

ENVIRONMENT PROTECTION

After the product lifespan expired or if the possible repairing is uneconomic, dispose it according to the local laws and environmentally friendly in the nearest scrapyards.

By proper disposal you will protect the environment and natural sources. Moreover, you can help protect human health. If you are not sure in correct disposing, ask local authorities to avoid law violation or sanctions.

TERMS AND CONDITIONS OF WARRANTY, WARRANTY CLAIMS

General Conditions of Warranty and Definition of Terms

All Warranty Conditions stated here under determine Warranty Coverage and Warranty Claim Procedure. Conditions of Warranty and Warranty Claims are governed by Act No. 89/2012 Coll. Civil Code, and Act No. 634/1992 Coll., Consumer Protection, as amended, also in cases that are not specified by these Warranty rules.

The seller is SEVEN SPORT s.r.o. with its registered office in Strakonická street 1151/2c, Prague 150 00, Company Registration Number: 26847264, registered in the Trade Register at Regional Court in Prague, Section C, Insert No. 116888.

According to valid legal regulations it depends whether the Buyer is the End Customer or not.

“The Buyer who is the End Customer” or simply the “End Customer” is the legal entity that does not conclude and execute the Contract in order to run or promote his own trade or business activities.

“The Buyer who is not the End Customer” is a Businessman that buys Goods or uses services for the purpose of using the Goods or services for his own business activities. The Buyer conforms to the General Purchase Agreement and business conditions.

These Conditions of Warranty and Warranty Claims are an integral part of every Purchase Agreement made between the Seller and the Buyer. All Warranty Conditions are valid and binding, unless otherwise specified in the Purchase Agreement, in the Amendment to this Contract or in another written agreement.

Warranty Conditions

Warranty Period

The Seller provides the Buyer a 24 months Warranty for Goods Quality, unless otherwise specified in the Certificate of Warranty, Invoice, Bill of Delivery or other documents related to the Goods. The legal warranty period provided to the Consumer is not affected.

By the Warranty for Goods Quality, the Seller guarantees that the delivered Goods shall be, for a certain period of time, suitable for regular or contracted use, and that the Goods shall maintain its regular or contracted features.

The Warranty does not cover defects resulting from (if applicable):

- User's fault, i.e. product damage caused by unqualified repair work, improper assembly, insufficient insertion of seat post into frame, insufficient tightening of pedals and cranks
- Improper maintenance
- Mechanical damages
- Regular use (e.g. wearing out of rubber and plastic parts, moving mechanisms, joints, wear of brake pads/blocks, chain, tires, cassette/multi wheel etc.)
- Unavoidable event, natural disaster
- Adjustments made by unqualified person
- Improper maintenance, improper placement, damages caused by low or high temperature, water, inappropriate pressure, shocks, intentional changes in design or construction etc.

Warranty Claim Procedure

The Buyer is obliged to check the Goods delivered by the Seller immediately after taking the responsibility for the Goods and its damages, i.e. immediately after its delivery. The Buyer must check the Goods so that he discovers all the defects that can be discovered by such check.

When making a Warranty Claim the Buyer is obliged, on request of the Seller, to prove the purchase and validity of the claim by the Invoice or Bill of Delivery that includes the product's serial number, or eventually by the documents without the serial number. If the Buyer does not prove the validity of the Warranty Claim by these documents, the Seller has the right to reject the Warranty Claim.

If the Buyer gives notice of a defect that is not covered by the Warranty (e.g. in the case that the Warranty Conditions were not fulfilled or in the case of reporting the defect by mistake etc.), the Seller is eligible to require a compensation for all the costs arising from the repair. The cost shall be calculated according to the valid price list of services and transport costs.

If the Seller finds out (by testing) that the product is not damaged, the Warranty Claim is not accepted. The Seller reserves the right to claim a compensation for costs arising from the false Warranty Claim.

In case the Buyer makes a claim about the Goods that is legally covered by the Warranty provided by the Seller, the Seller shall fix the reported defects by means of repair or by the exchange of the damaged part or product for a new one. Based on the agreement of the Buyer, the Seller has the right to exchange the defected Goods for a fully compatible Goods of the same or better technical characteristics. The Seller is entitled to choose the form of the Warranty Claim Procedures described in this paragraph.

The Seller shall settle the Warranty Claim within 30 days after the delivery of the defective Goods, unless a longer period has been agreed upon. The day when the repaired or exchanged Goods is handed over to the Buyer is considered to be the day of the Warranty Claim settlement. When the Seller is not able to settle the Warranty Claim within the agreed period due to the specific nature of the Goods defect, he and the Buyer shall make an agreement about an alternative solution. In case such agreement is not made, the Seller is obliged to provide the Buyer with a financial compensation in the form of a refund.

CZ
SEVEN SPORT s.r.o.

Registered Office: Strakonická 1151/2c, Praha 5, 150 00, ČR
Headquarters: Dělnická 957, Vítkov, 749 01
Warranty & Service: Čermenská 486, Vítkov 749 01

CRN: 26847264
VAT ID: CZ26847264
Phone: +420 556 300 970
E-mail: eshop@insportline.cz
reklamace@insportline.cz
servis@insportline.cz

Web: www.inSPORTline.cz

SK
inSPORTline s.r.o.

Headquarters, warranty & service center: Električná 6471,
Trenčín 911 01, SK

CRN: 36311723
VAT ID: SK2020177082
Phone: +421(0)326 526 701
E-mail: objednavky@insportline.sk
reklamacie@insportline.sk
servis@insportline.sk

Web: www.inSPORTline.sk

About shipping

